

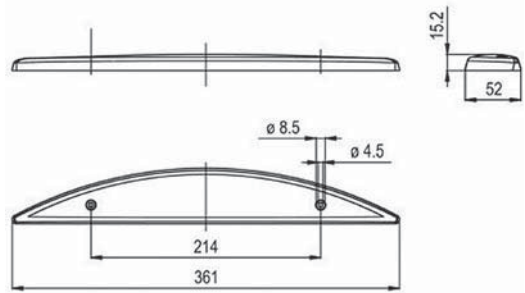



Weitere Leuchten aus dieser Kategorie finden Sie im Kapitel „LEUCHTEN-SYSTEME“ * For further lights of this series please refer to chapter „LIGHTING SYSTEMS“





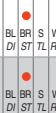

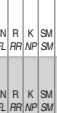
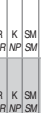
LED-ZUSATZBREMSLEUCHE ZHBL 25 mit KLARGLASOPTIK * LED HIGH LEVEL STOP LIGHT ZHBL 25 with CLEAR OPTICS

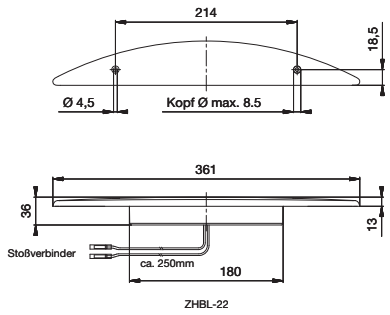

<ul style="list-style-type: none"> · Aufbau-Montage mit Schraubbefestigung · 11 Leuchtdioden · wasserdicht vergossen und anschlussfertig 				<ul style="list-style-type: none"> · surface mounting with screws · 11 LED's · sealed in a waterproof manner and ready for plug-in 							
Bild Picture	Art.-Nr. / No. Typ / Type	Beschreibung Description	Merkmale Features	Spann. Voltage	Leistung Power	Material / Farbe Material / Colour	Anschluss Connection	Gewicht Weight	IP / Temp. IP / Temp.	VP PU	Homolog. Approval
	15.0025.002 ZHBL 25/12	LED-Zusatzbremsleuchte LED High Level Stop Light		12 V	1,6 W	PMMA / ABS rot - red	Kabel 250 mm cable 250 mm	0,11 kg	IP67	50 E/75	S3 E2- 0205026
	15.0025.502 ZHBL 25/24	LED-Zusatzbremsleuchte LED High Level Stop Light		24 V	2,0 W	PMMA / ABS rot - red	Kabel 250 mm cable 250 mm	0,11 kg	IP67	50 E/75	S3 E2- 0205026
	15.0025.202 ZHBL 25/12	LED-Zusatzbremsleuchte LED High Level Stop Light		12 V	1,6 W	PMMA / ABS klar - clear	Kabel 250 mm cable 250 mm	0,11 kg	IP67	50 E/75	S3 E2- 0205026
	15.0025.702 ZHBL 25/24	LED-Zusatzbremsleuchte LED High Level Stop Light		24 V	2,0 W	PMMA / ABS klar - clear	Kabel 250 mm cable 250 mm	0,11 kg	IP67	50 E/75	S3 E2- 0205026

LED-ZUSATZBREMSLEUCHE ZHBL 22 mit KLARGLASOPTIK * LED HIGH LEVEL STOP LIGHT ZHBL 22 with CLEAR OPTICS



<ul style="list-style-type: none"> · Einbau-Montage mit Schraubbefestigung · 11 Leuchtdioden · wasserdicht vergossen und anschlussfertig 				<ul style="list-style-type: none"> · flush fitting with screws · 11 LED's · sealed in a waterproof manner and ready for plug-in 							
Bild Picture	Art.-Nr. / No. Typ / Type	Beschreibung Description	Merkmale Features	Spann. Voltage	Leistung Power	Material / Farbe Material / Colour	Anschluss Connection	Gewicht Weight	IP / Temp. IP / Temp.	VP PU	Homolog. Approval
	15.0022.003 ZHBL 22/12	LED-Zusatzbremsleuchte LED High Level Stop Light		12 V	1,3 W	PMMA / ABS rot - red	Flachsteckungen blade terminals	0,11 kg	IP67	10 E/50	S3 E4- 027606
	Zusatz-Information: Additional Information:		Kabel 250 mm, Stoßverbinder cable 250 mm, butt connector								

Zubehör / Ersatzteile * Accessories / Spare parts

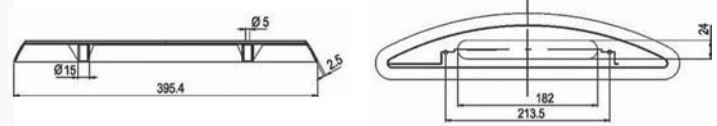

	19.2018.000 ZHBL 22-wsF	Anbau Sockel Distance base	15.0022.....			ABS weiß - white		0,10 kg		20 E/6	
---	-----------------------------------	-------------------------------	--------------	--	--	---------------------	--	---------	--	-----------	--

	in Einzelverpackung erhältlich! available in individual packaging!	Art.-No. / CODE - XX.XXXX.XXX E		Einzelverpackungen auch im Sammelkarton mit xxx Stück erhältlich! individual packaging available in a collective box with xxx pieces!
---	---	---------------------------------	---	--