

Maniglia per portelloni - Luggage door handles

P.119

- Materiale - Material**
Poliammide fibra vetro + anti-UV
Glass fibre polyamide + anti-UV
- Colore - Colour**
Nero - Black
- Pezzi confezione - Package items**
25 pezzi - pieces
- Volume confezione - Package volume**
35,2 dm³
- Peso confezione - Package weight**
P.119 m - e - (all versions) = 9.750 g
P.119 pn - (all versions) = 11.700 g
- Ricambi - Spare parts**
vedi sez. tecnica - see technical section
- Accessori - Accessories**
vedi sez. tecnica - see technical section
- Carico di rottura - Breakup load**
2.000 N
- Temp. di esercizio - Working temp.**
-10/+120 °C
- Normative - Norms**
pag. A4



P.119	m manual	pn pneumatic	e electric			
	Cod.	Cod.	Cod.			
A01 - 137	51221	52441	69447	•		
A02 - 146	51231	52451	69457	•		
A03 - 150	51241	52461	69467	•		
A04 - 124	52131	52161	69477	•		
A05 - 501	68515	68575	69487	•		
A06 - 502	68525	68585	69497	•		
A07 - 250	68535	68595	69507	•		
A08 - 262	68545	68605	69517	•		
A09 - 269	68555	68615	69527	•		
A10 - 278	68565	68625	69537	•		
A11 - 156	61828	61848	62109	•		
A12 - 142	61838	61858	68419	•		
A13 - 503	62918	69469		•		
A14 - 504	62928	69479		•		
A15 - 505	62938	69489		•		
A16 - 506	62948	69499		•		
A17 - 507	62958	69509		•		
A18 - 508	62968	69519		•		
A19 - 509	62978	69529		•		
A20 - 510	62988	69539		•		
A21 - 511	62998	63158		•		
A22 - 512	63008			•		
A23 - 513	63018			•		
A24 - 514	63028			•		
A25 - 515	63038			•		
A26 - 516	63048			•		
A27 - 517	63058			•		
A28 - 518	63068			•		
A29 - 519	64588			•		
A30 - 520	64598			•		
A31 - 521	64608			•		

P.119	m manual	pn pneumatic	e electric			
	Cod.	Cod.	Cod.			
A32 - 522	64618			•		
A33 - 523	64628			•		
A34 - 524	64638			•		
A35 - 525	64648	60662		•		
A36 - 526	64658	69411		•		
A37 - 527	64668			•		
A38 - 528	64678			•		
A39 - 529	65528			•		
A40 - 530	65538			•		
A41 - 145	68571			•		
A42 - 152	67721	67751		•		
A43 - 147	67731	67761	69691	•		
A44 - 149	63131		63141	•		
A45 - 148	67741	67771	67771	•		
A46 - 151	61871	67781	67781	•		
A47 - 163	64612			•		
A48 - 176	64622			•		
A49 - 186	64632			•		
PS200		62261		•		
J1	64399	66960	61661	•		
J2	66129	61901	No	•		

serratura già inserita, chiave rimovibile con man. chiusa e aperta (m, pn) o solo chiusa (e)
lock already fitted, key removable with locked and unlocked handle (m, pn) or only locked (e)

J1-J2 Sez. Tecnica (inserimento P.474) - Technical section (assembly P.474)

materiale disponibile a stock - material available on stock

materiale non disponibile a stock - material not available on stock

lotto minimo d'acquisto - minimum purchasing lot

versione a richiesta - version available on request

P.119

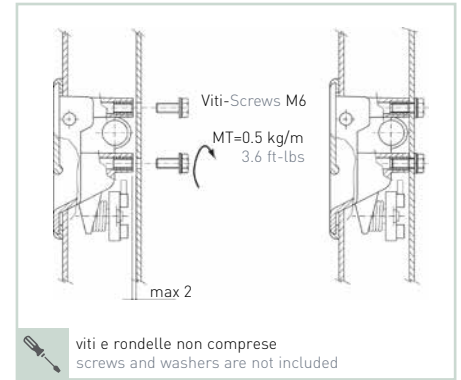
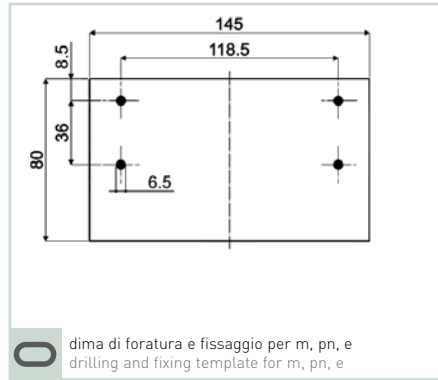
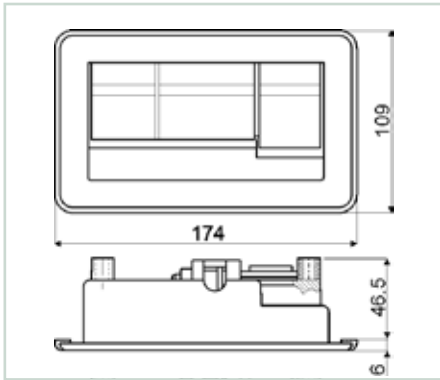

O dima di foratura e fissaggio per m, pn, e
drilling and fixing template for m, pn, e

viti e rondelle non comprese
screws and washers are not included

■ Inserimento - Assembly P.474 for J1m, J1pn, J1e

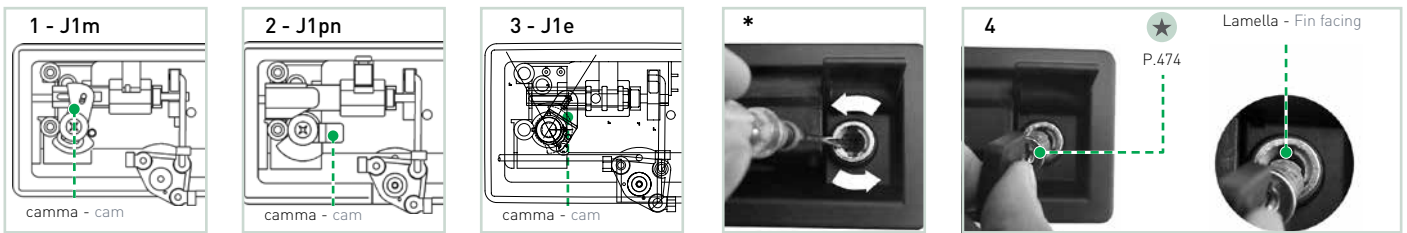

- 1, 2, 3 Verificare corretta posizione camma * Se non OK, ruotare in senso anti-orario il "quadro" sul fondo dello statore sino a fine corsa
- 4 Inserire la serratura con la lamella rivolta verso lo scivolo (ulteriori info pag.A3), previo ingrassaggio preliminare - Chiave removibile solo con maniglia chiusa
- 1, 2, 3 Check if cam is in "closed" position * If not, turn the "square" at the bottom of the stator, anti-clockwise until end-stroke position.
- 4 Insert the lock as shown with the fin facing the chute (more info page A3), after preliminary greasing - Removable key with locked handle

■ Inserimento - Assembly P.474 for J2m, J2pn



- 5, 6 Verificare corretta posizione camma - * Se non OK ruotare in senso orario il "quadro" sul fondo dello statore sino a fine corsa.
- 7 Inserire la serratura con la lamella rivolta verso lo scivolo (ulteriori info pag.A3), previo ingrassaggio preliminare - Chiave removibile sia con maniglia chiusa che aperta
- 5, 6 Check if cam is in "open" position. - * if not, turn the "square" at the bottom of the stator, clockwise until end-stroke position.
- 7 Insert the lock as shown with the fin facing the chute (more info page A3), after preliminary greasing - Removable key with locked and unlocked handle

■ Schemi chiusura pneumatica ed elettrica - Pneumatic and electric diagram Sez. B pag B9 - B13

■ Esempi d'applicazione - Examples of application

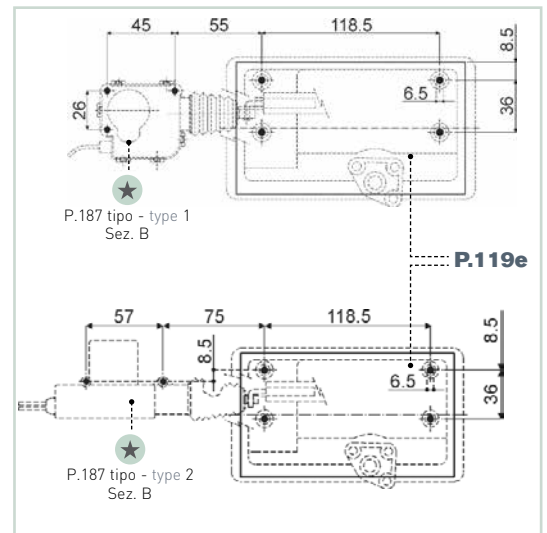
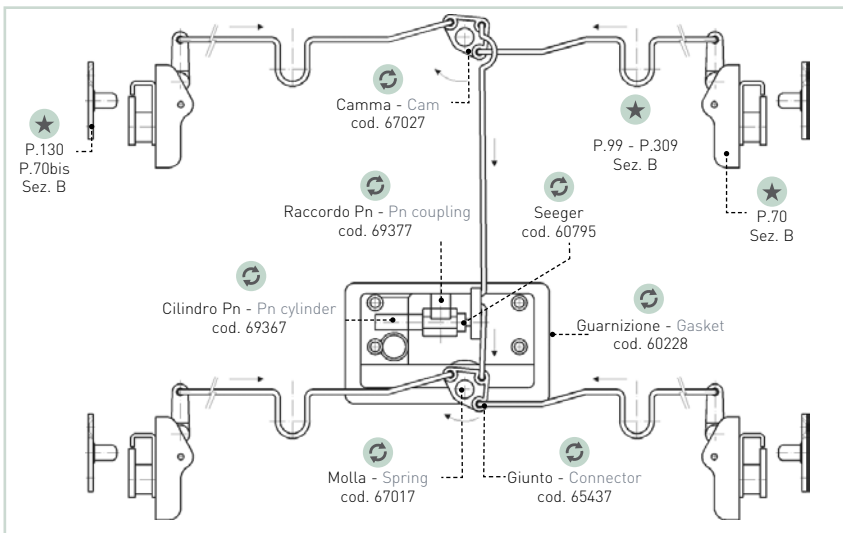

A