

P.318

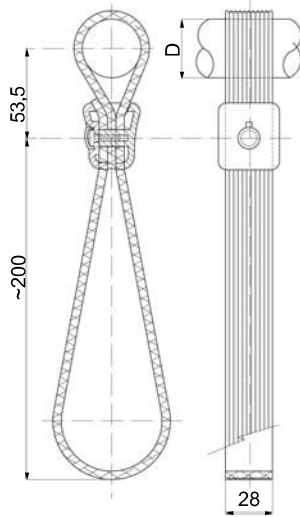

Boccola- bushing



Caratteristiche - Features



Fascia in PVC
Ferma fascia in poliammide rinforzata
Boccola in poliammide rinforzata
PVC band
Band stop in reinforced polyamide
Bushing in PA6+FG



Secondo codice - According to item code



50 pezzi - pieces



35 dm³



Secondo codice - According to item code



4 - 8 (pag.28)



Sezione tecnica - Technical section
pag. 42 - 36

Versioni disponibili / Available versions

P.318	maniglia di presa per bus urbani - catching handle for urban buses							
Cod.	Colore Fascia - Band Colour	Dmm	Colore Boccola - Bushing Colour					
60879	grigio / grey Ral 7012	Ø 30	nero / black	7.900	•		500	
60081	giallo / yellow Ral 1023							
67969	grigio / grey Ral 7012		grigio / grey Ral 7012					
65701	grigio / grey Ral 7012	Ø 32	nero / black	7.900	•		500	
66199	grigio / grey Ral 7012		-	7.000	•		500	
67098	grigio / grey Ral 7012	Ø 35	-	7.000	•		500	
61651	verde / green Ral 6029		-					

P.260

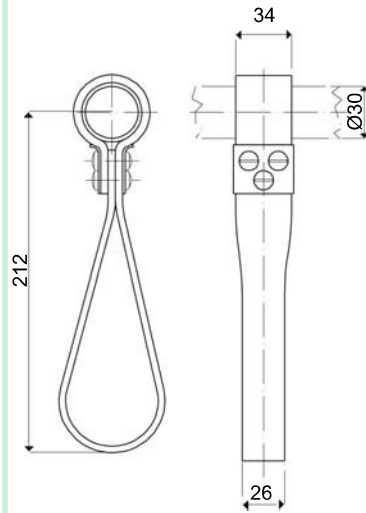

Caratteristiche - Features



Fascia in cuoio nero
Piastrina in Acciaio brunito
Viti M6 in ottone nichelato
Black Leather band
Burnished iron plate
Special nickel-plated screws



Nero - black



50 pezzi - pieces



24,3 dm³



4.800 g



-



Sezione tecnica - Technical section
pag. 42 - 36

Versioni disponibili / Available versions

P.260	maniglia di presa per bus urbani - catching handle for urban buses							
Cod.								
61688					•			

Altri diametri a richiesta - different diameters on request

P318



boccola Ø 30 solo nei cod.
bushing Ø 30 only in code
cod. 60879
cod. 60081
cod. 67969

boccola Ø 32 solo nel cod.
bushing Ø 32 only in code
cod. 65701

vite autofilettante a testa piana Ø 3,9x16
Ø 3,9x16 autothreading button head screws



Foto a lato
See picture



Fissaggio con vite compresa nella confezione.
Fixing screws included in the package.

Caratteristiche - Features



Temperatura di esercizio: 10/70°C
Working temperature: 10/70°C



Carico massimo di rottura a trazione statica per:
Cod. 61651=1692 N
Cod. 60081=2210 N
Cod. 60789=2210 N
Cod. 66199=2210 N
Cod. 67098=2210 N
Cod. 67969=2210 N

Static traction breaking load for:
Cod. 61651=1692 N
Cod. 60081=2210 N
Cod. 60789=2210 N
Cod. 66199=2210 N
Cod. 67098=2210 N
Cod. 67969=2210 N

P260



viti speciali / special screws

rivetti / rivets



Foto a lato
See picture



Fissaggio con viti e rivetti compresi nella confezione.
Fixing screws and rivets included in the package.

Caratteristiche - Features



Temperatura di esercizio: -10/120°C
Working temperature: -10/120°C



Carico massimo di rottura a trazione statica 2000 N
Static traction breaking load 2000 N